

PARENTS, YOUNGSTERS & ALL-TERRAIN VEHICLES



**PARENTS,
YOUNGSTERS &
ALL-TERRAIN
VEHICLES**



Parents, Youngsters & All-Terrain Vehicles

U.S. Version • Revised 5/24 • © 2024 Specialty Vehicle Institute of America



It is important for parents to help their youngsters understand and follow the instructions and warnings in the All-Terrain Vehicle's (ATV's) owner's manual and on its labels. This booklet contains additional information and guidelines that can help make ATV riding a safe and enjoyable family experience. ATVs handle differently from other vehicles such as motorcycles and cars. Proper instruction and practice are important.

ATVs can be hazardous to operate. For your safety, always wear a helmet and other protective gear. Never ride on public roads – another vehicle could hit you. Never ride under the influence of alcohol or other drugs. Never carry a passenger on a single-

For more information contact:

2 Jenner, Suite 150 • Irvine, California 92618-3812
949.727.3727 • atvsafety.org

To enroll in the ATV *RiderCourse* nearest you, visit atvsafety.org/reserve-your-seat or call 800.887.2887

rider vehicle. Ride an ATV that's right for your age. Supervise riders younger than 16; ATVs are not toys. Ride only on designated trails and at a safe speed. Take the online E-Course then attend the hands-on skills portion of the ATV *RiderCourse*. Visit atvsafety.org or call toll-free 800.887.2887.

The ATV Safety Institute (ASI) is a division of the Specialty Vehicle Institute of America, a national not-for-profit association representing U.S. distributors of all-terrain vehicles. Supporting members are: BRP, CFMOTO, Coleman Powersports, Honda, Kawasaki, Polaris, Suzuki, Textron, and Yamaha.

We know that you, as a parent, will have your youngster's safety foremost in mind. ATVs are not toys. Serious injury can result from improper use of All-Terrain Vehicles (ATVs). Your youngster's safety will depend on you taking a "safety-first" approach to ATV riding at all times.

The first step in this approach is to determine your youngster's readiness to ride an ATV. **Parents, Youngsters and All-Terrain Vehicles** can assist you in making this important decision. In addition to the information provided in this booklet, it is important to carefully read and follow the instructions and warnings in the ATV owner's manual and on labels.

ATVs handle differently from other vehicles such as motorcycles and cars. Proper instruction and practice are important. The *ATV RiderCourse*SM, an online plus hands-on training program, is available nationwide. The online E-Course is free to everyone. If you purchased a new ATV, you may also be eligible for free hands-on training. Once training is completed, you may also be eligible to receive an incentive. To find out if you

are eligible for free hands-on training, contact the ATV Enrollment Express at 800.887.2887. To enroll in the *ATV RiderCourse* nearest you, visit atvsafety.org/reserve-your-seat or call 800.887.2887. Those not eligible for free hands-on training may take the course for a reasonable fee. We recommend that you take advantage of the training programs, and have your youngster perform the exercises in this booklet.

Be sure the ATV is recommended for your youngster's age group.

Do not permit youngsters to ride an ATV that is larger than recommended for their age group. Remember that riders under 16 years of age must be supervised by an adult. If you have a youngster who is about ready to ride an ATV, there are special considerations that you should keep in mind.

Although a child may be of the recommended age to ride a particular size ATV, not all youngsters have the strength, skills or judgment needed to operate an ATV. You should supervise your youngster's operation of the ATV at all times and should allow

continued use only if you determine that your youngster has the ability and judgment to operate the ATV safely.

Do not permit your youngster to operate a two-up vehicle. If you permit your youngster to be a

passenger on a two-up vehicle, operated by a responsible adult familiar with the operation of that vehicle, your youngster must be able to reach the handholds and place feet on footrests from a seated position in the designated passenger's seat, and wear all protective gear.

ALWAYS Follow the Manufacturer's Minimum Age Recommendation Warning Label on the ATV.







<p>▲ WARNING</p>  <p>Operation of this ATV by children under the age of 6 increases the risk of severe injury or death.</p> <p>Adult supervision required for children under age 16.</p> <p>NEVER permit children under age 6 to operate this ATV.</p>	<p>▲ WARNING</p>  <p>Operation of this ATV by children under the age of 10 increases the risk of severe injury or death.</p> <p>Adult supervision required for children under age 16.</p> <p>NEVER permit children under age 10 to operate this ATV.</p>	<p>▲ WARNING</p>  <p>Operation of this ATV by children under the age of 12 increases the risk of severe injury or death.</p> <p>Adult supervision required for children under age 16.</p> <p>NEVER permit children under age 12 to operate this ATV.</p>	<p>▲ WARNING</p>  <p>Operation of this ATV by children under the age of 14 increases the risk of severe injury or death.</p> <p>Adult supervision required for children under age 16.</p> <p>NEVER permit children under age 14 to operate this ATV.</p>	<p>▲ WARNING</p>  <p>Operating this ATV if you are under the age of 16 increases your chance of severe injury or death.</p> <p>NEVER operate this ATV if you are under age 16.</p>	
<p>Two-up ATVs will have this label</p>					<p>▲ WARNING</p>  <p>Operating this ATV if you are under the age of 16 increases the chances of severe injury or death to both operator and passenger.</p> <p>NEVER operate this vehicle if you are under age 16.</p>

TABLE OF CONTENTS

INTRODUCTION

Purpose of the Booklet.....	1
Important Notes to Parents	1
Other Sources of Information	1

PART 1

Determining Your Youngster's Readiness to Ride an ATV

Readiness Guidelines	2
Steps for Safe and Responsible ATV Riding	6

PART 2

Pre-Operating Procedures and Practice

Protective Gear and Clothing	7
Mounting/Dismounting	8
Mastering the Controls.....	10
Learning Activities	12

PART 3

Operating Procedures and Practice

Learning Area/Riding Area.....	16
Getting Used to the Vehicle in Motion.....	18
Let's Start Riding	21

PART 4

Readiness Checklist

Visual Perception/Motor Development ...	24
Physical Development	25
Social/Emotional Development.....	26
Reasoning and Decision-Making Ability.....	28

FINAL NOTE

To Parents	30
Glossary.....	33
Answers.....	36

Purpose of the Booklet

Parents, Youngsters and All-Terrain Vehicles is intended to assist you in determining if your youngster is ready to ride all-terrain vehicles (ATVs). It also provides important safety information and tips on learning to ride. This booklet is divided into four parts:

- Part 1:** Determining Your Youngster's Readiness To Ride An ATV
- Part 2:** Pre-Operating Procedures
- Part 3:** Operating Procedures
- Part 4:** Readiness Checklist

There is information about protective gear, control operation and starting the engine. Operating procedures include starting out, shifting, stopping and turning.

Important Note to Parents

Once your youngster is ready to learn to ride, YOU must be familiar with the ATV. You will be serving as teacher, coach, and safety supervisor for your youngster. You must know the controls, handling characteristics, maintenance requirements, and proper riding techniques. Read and understand

the owner's manual, the hang tags, and labels provided with the vehicle. Make sure that the ATV to be ridden is one that is recommended for use by your youngster's age group. Review all instructions, requirements and warnings with your youngster. Find out about state or local ATV laws or regulations. You and your youngster can take the ATV Safety Institute *ATV RiderCourse* in your area. Start by taking a fun and informative E-Course to learn basic ATV safety principles. The E-Course can be found on our website, atvsafety.org. To enroll in the *ATV RiderCourse* nearest you, visit atvsafety.org/reserve-your-seat or call 800.887.2887.

Other Sources of Information

In addition to the information provided in **Parents, Youngsters and All-Terrain Vehicles**, there are other sources of safety information. The owner's manual provides specific maintenance and operating procedures for your ATV. It also includes warnings, cautions, and operating tips. ATV dealers have product literature and safety information.

DETERMINING YOUR YOUNGSTER'S READINESS TO RIDE AN ATV

2

Readiness Guidelines

Another booklet, *Tips and Practice Guide for the All-Terrain Vehicle Rider*, gives detailed riding procedures for older riders.

The first important decision you will need to make concerning your youngster and ATVs is whether your youngster is ready to ride. ALWAYS follow the manufacturer's Minimum Age Recommendation Warning Label on the ATV. Physical size, strength, coordination, visual perception, emotional maturity, and the ability to reason and make good decisions are equally important considerations.

There is no sure way to predict whether your child will be able to ride an ATV safely. However, the following guidelines can help you determine your youngster's readiness to ride. Remember, only parents can decide if their youngster has the capabilities and qualities to safely operate an ATV.

PHYSICAL DEVELOPMENT

Physical size and ability are important considerations. To help determine whether a

youngster is big enough for a particular ATV, have him/her stand up on the footrests and grasp the handgrips. While the youngster holds this position, check that there are at least three inches of clearance between the ATV seat and the youngster's "seat of the pants." A rider needs at least three inches of clearance so he/she can stand up for balance and comfort, and to shift his/her body forward, backward and from side to side.



Also make sure your youngster can comfortably reach and work all the controls. For example, can he/she turn the handlebars all the way to the right and left? Can he/she easily use their feet to work the brake pedal and gearshift lever? Can he/she operate the throttle and brake levers while they hold onto the handgrips? If not, the youngster may not be able to maintain balance and control and is not physically ready to ride this ATV.

Athletic ability is another consideration for riding an ATV. Generally speaking, your youngster should be good at riding a bicycle before he/she gets on an ATV. Can your youngster judge speeds and distances while riding a bicycle and react with proper hand and foot actions? Anyone who does not have good coordination, balance and agility is not ready to ride an ATV.



DETERMINING YOUR YOUNGSTER'S READINESS TO RIDE AN ATV

4

SOCIAL/EMOTIONAL DEVELOPMENT

How a youngster behaves in a social setting can be a sign of social/emotional development. A youngster needs to know about and understand rules. Certain rules are necessary for the safe operation of any vehicle. Youngsters must be willing to follow rules. A good example is a youngster who obeys rules set by parents. A youngster who does not follow rules is not ready for an ATV.

One indicator that youngsters are ready to ride an ATV is when they demonstrate safety-conscious attitudes and are aware of possible injury from reckless ATV operation. If the youngster has a habit of recklessness or is often involved in accidents while using bicycles or skateboards, the youngster is not ready to ride an ATV.

REASONING AND DECISION-MAKING ABILITY

Youngsters should understand what can result from improper ATV operation. They must understand that unsafe actions can result in injury. An example of this is knowing the need to look in both directions before crossing a street. The ability to make good decisions relates to a youngster's ability to reason. When presented with a problem, the youngster should be able to come up with a sensible answer. Ask your youngster to tell you what causes accidents and injuries. Your youngster needs to be able to tell what causes accidents and how to avoid them. In general, a youngster should understand that he or she can get hurt as a result of making poor choices. Your youngster should understand that it's dangerous to mimic the extreme stunts professional riders exhibit on TV and in video games.

VISUAL PERCEPTIONS AND MOTOR DEVELOPMENT

Visual perception and motor development is how well a youngster sees and how vision is used with other physical movements. In other words, can a youngster see and react with the proper hand, foot, or body movement?

Several types of sight-ability characteristics are important. The ability to see to the sides while looking straight ahead is called peripheral or side vision. You can determine a youngster's side vision by having him or her look straight ahead while you move objects to the side. The youngster should be able to see objects 90 degrees to the side while looking straight ahead. Rider awareness and safety improves with good side vision.

Being able to judge distance is another visual skill helpful when operating an ATV. Is your youngster able to tell how far one object is from another, or which of two objects is closer? ATV riding requires a person to judge distance and react properly.

Being good at playing video games, or being able

to hit a baseball, for example, are good signs that a youngster's eye and hand movements are fairly well coordinated.

In summary, you must consider many things before you decide to put your youngster on an ATV. There is no exact formula to use in making that decision. The Readiness Checklist, Part 4, can assist you with some points to evaluate. If you are not able to check most of the statements, your youngster is probably not ready to ride an ATV.

DETERMINING YOUR YOUNGSTER'S READINESS TO RIDE AN ATV

6

Steps for Safe and Responsible ATV Riding

Once you determine that ATV use is proper for your youngster, it is time to prepare yourself to be a good ATV teacher and supervisor.

STEP 1: EDUCATE YOURSELF ABOUT ATV SAFETY AND PROPER RIDING TECHNIQUES

You must learn as much as possible about ATVs in general and especially your youngster's ATV. You must be qualified to instruct and supervise your youngster. This means that you will need to understand the features of the ATV and the proper riding techniques. The best source of reference is the owner's manual supplied with the ATV. Read the owner's manual before you begin to instruct your youngster about ATV safety. Pay particular attention to the warning labels on the ATV. For a "hands-on" learning experience consider taking the *ATV RiderCourse*.

STEP 2: TEACH YOUR YOUNGSTER SAFE AND PROPER RIDING TECHNIQUES

Teaching your youngster ATV safety is a step-by-step process. It begins with safety rules and moves to actual riding procedures. Since youngsters learn at different rates, it will be up to you to set the pace of your youngster's progress. At some point you may decide that he or she is not ready to ride an ATV.

STEP 3: AVOID UNSAFE SITUATIONS THROUGH CLOSE SUPERVISION

ALWAYS closely supervise your youngster's riding. This is needed even if your youngster has learned and mastered the rules and skills of safe ATV riding. Youngsters can get tired easily and become careless. They do not always see everything that is important around them. Your close supervision and good judgment are important.

Protective Gear and Clothing

ATV riding demands that your youngster wear proper protective gear. ATV riders should ALWAYS wear a helmet, eye protection, gloves, long pants, a long-sleeved shirt or jacket, and over-the-ankle boots. Anything less is not adequate protection. NEVER let anyone ride an ATV without a Department of Transportation (DOT) compliant motorcycle helmet. Be sure it fits correctly. It should be snug but not tight. It must be properly fastened.

Protective gear is necessary in any weather, even when the temperature is warm. In cold weather you should dress your youngster with additional layers of clothing. Some riders wear a kidney belt and chest or back protector for additional protection. Adjacent is a picture of well-equipped riders. Show this picture to your youngster and point out what is important.

Consider using hearing protection such as disposable foam earplugs on longer rides.



PRE-OPERATING PROCEDURES AND PRACTICE

8

Mounting/Dismounting

Have your youngster wear safety gear whenever getting on an ATV. This action will stress the importance of safety gear and help to develop safe riding habits.

To properly mount the ATV, first check that the parking brake is set. Mounting is from the side, putting the left foot on the footrest (if mounting from the left). Be careful not to step on the shift lever (if the vehicle is equipped with one). The other leg is swung over the seat and placed on the other footrest. Care should be taken to rest the feet in the middle of the footrests. This allows correct use of the shift lever and the rear brake. Once mounted, the youngster should assume the correct riding posture. Dismounting reverses the mounting procedure. With the parking brake set, the leg is swung over the seat onto the ground. The other foot is then removed from the footrest.

Correct riding posture helps your youngster operate the controls. Proper straight-line riding posture includes:

- Head and eyes up, looking well ahead.
- Shoulders relaxed, back straight.
- Elbows bent, slightly out and away from the body.
- Hands on the handlebars.
- Knees in.
- Feet on the footrests, toes pointing straight ahead.

The hand and foot controls are important to riding safely. Both hands should be kept on the handlebars and both feet on the footrests. Removing a hand or foot can reduce the rider's ability to control the ATV. Removing a foot from a footrest can result in a foot or leg coming in contact with a rear wheel.

ATVs are rider-active; to enhance the performance capabilities of the ATV, a rider must shift body weight. This is especially true in maneuvers such as turning, negotiating hills, and riding on bumpy terrain. Your youngster should be able to operate the controls during these maneuvers. Now is a good time to make sure your youngster can reach the controls from different body positions. Have the youngster remount and turn the handlebars all the way to the left and right. See that this can be done easily. Next, have the youngster slide up and back on the seat. Mention that body movement is important. Body movement and shifting weight help to control the ATV, which is why passengers should never be allowed on a single-rider ATV.



PRE-OPERATING PROCEDURES AND PRACTICE

Mastering the Controls

GO THROUGH THESE EXERCISES WITH THE ATV'S ENGINE OFF.

Show your youngster how to use each control as you describe its action. Refer to the owner's manual to learn control location and function before instructing your youngster. Test yourself by operating the controls. Have your youngster dress in the proper protective gear and sit on the machine as you point out each control. It is important to have your youngster wear all the protective gear whenever sitting on an ATV.

BRAKES

Many small ATVs have a hand lever on the left handlebar which operates the rear brake. Additionally, some have a foot pedal on the right side to operate the rear brake. Most ATVs have a front brake lever on the right handlebar. Refer to the owner's manual for correct brake location and operation.

Explain and demonstrate proper braking procedure.

Be sure your youngster can apply the brake(s) properly while seated and without looking down. Smooth operation should be encouraged.

The parking brake has several uses. It should be set before starting the ATV engine. It should be set while transporting the ATV and when parking the ATV. The drawing on page 13 shows one type of parking brake. Your ATV parking brake may be different; you should look in the owner's manual to find out how to use it.

THROTTLE CONTROL LEVER

Explain to your youngster that pushing the throttle control lever will make the ATV go faster. Easing back on the lever will cause the ATV to slow. Releasing the throttle control lever slows the ATV quickly, especially when the brakes are used.

Youngsters need practice using the throttle smoothly. They tend to use it like an on/off switch. With the engine off, have your youngster move the throttle lever to various positions. Practice turning the handlebars and using the throttle at the same time.

ENGINE STOP SWITCH

Explain to your youngster how to use the engine stop switch to turn off the engine. With the engine off, show how the stop switch works. It is used to stop the engine quickly. Later, your youngster can practice using the stop switch when the engine is actually running.

SHIFT LEVER

Many small ATVs do not have a shift lever. This section applies only to ATVs with a shift lever. Those that do have a shift lever may have different shift patterns. Refer to your owner's manual for proper shifting instructions. It is important to learn how the shift lever works.

Explain that it is possible to change gears with the shift lever in order to ride at different speeds. Have your youngster practice shifting with the engine off. Make sure he or she releases the throttle control lever before moving the shift lever, and releases the shift lever before pressing on the throttle. With the engine off, have your youngster practice upshifts, downshifts, and locating neutral.

Supervisor Control Features

REMOTE ENGINE STOP SWITCH

Some small ATVs come equipped with a remote engine stop switch, such as a tethered cord, that is controlled by a supervisor. This feature is used to stop the ATV engine by the supervisor should an unsafe situation develop. Check your owner's manual or ask your dealer if your youngster's ATV has this feature.

SPEED LIMITERS

On some ATVs, the maximum speed can be controlled by adjusting a throttle limiter to restrict the movement of the throttle control lever. Other models may use other methods, such as an intake or exhaust restrictor, or a combination of technologies to limit the maximum speed. Refer to your owner's manual and talk to your dealer about this.

LEARNING ACTIVITIES

Here are some activities that your youngster can use to help learn about ATV parts and controls.

12

ATV Crossword Puzzle

Here is a crossword puzzle for your youngster to complete. (The Answer Guide is on page 35.)

Across

1. What this booklet is all about.
2. A piece of safety equipment for the head that is always worn when riding.
3. Protective gear for your hands.
4. Where you should always ride your ATV.
5. Initials for an All-Terrain Vehicle.

Down

6. The place where you always keep your feet when riding an ATV.
7. Protective gear for your feet and ankles.

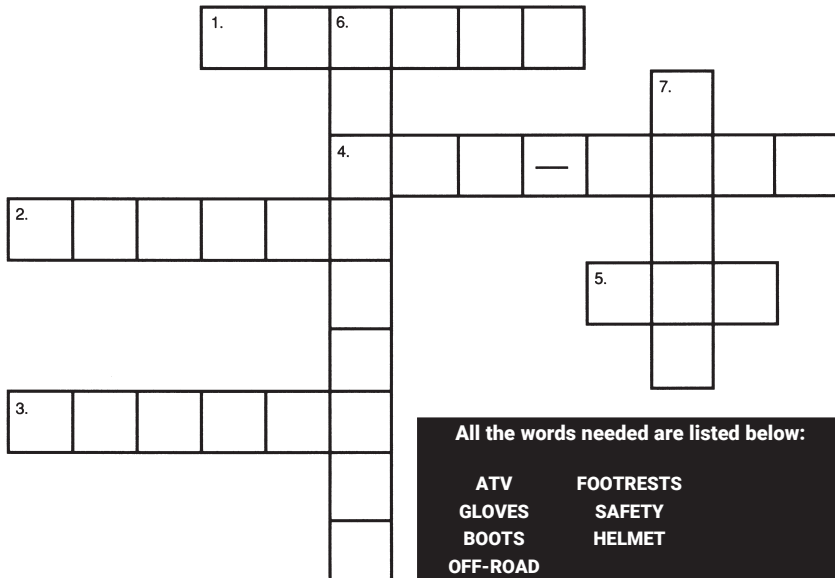

All the words needed are listed below:

ATV	FOOTRESTS
GLOVES	SAFETY
BOOTS	HELMET
OFF-ROAD	

Name The ATV Parts

Have your youngster write the number of the ATV part or control on the correct line for the diagrams shown. (The Answer Guide is on page 36.)

1. Parking Brake

2. Hand Brake Lever(s)

3. Foot Brake Pedal

4. Throttle

5. Ignition Switch

6. Choke (primer)

7. Engine Stop Switch

8. Gas Cap/Tank Vent

9. Starter (pull, kick, electric)

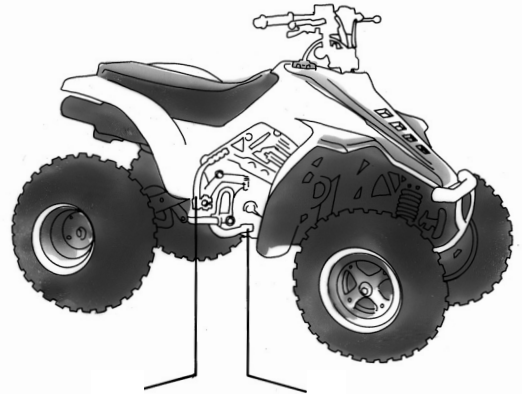
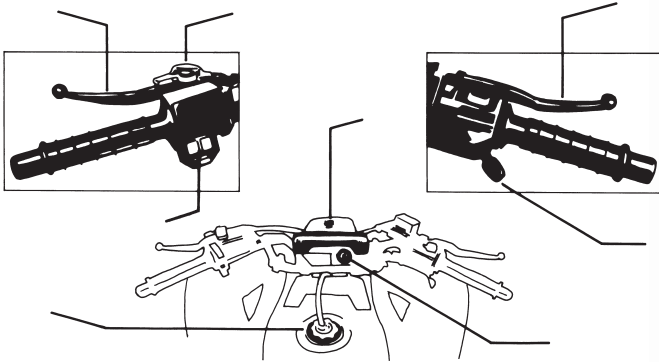

LOCATING THE CONTROLS GAME

14

Now that you have shown your youngster the controls, it is your youngster's turn to show you. The engine remains OFF for this exercise and your youngster will be on the machine. The youngster should be wearing the proper protective gear to help develop this safety habit.

1. Have your youngster show you the location of the following:
 - Parking Brake
 - Brake (lever(s) and pedal)
 - Throttle Control Lever
 - Engine Stop Switch
 - Shift Lever (if equipped)
2. Have your youngster show you how the controls work. Be sure he or she understands the proper operation of each control. Skilled use of these controls should develop with practice. Under actual riding conditions, the rider will have to watch ahead while operating the controls. Your youngster should be able to find the controls quickly without looking for them.
3. With your youngster looking ahead (pick out a point to look at), have him or her operate the controls. Repeat often while changing the order.
4. Ask your youngster to operate the controls as if actually riding. Look for smooth and precise operation.

Before you continue:

1. Have you determined your youngster's readiness to ride an ATV? Do not let your youngster ride if you have any doubt. (Refer to the Readiness Checklist, Part 4.)
2. Have you read the owner's manual and reviewed it with your youngster?
3. Have you confirmed that the ATV to be ridden is one that is recommended for use by your youngster's age group? (See page iii.)
4. Have you inspected the vehicle and maintained it according to the owner's manual?
5. Is your youngster wearing the proper protective gear? Is his or her mounting procedure correct?
6. Has your youngster learned to locate the ATV controls without looking at them? Does he or she know how to operate them smoothly?
7. Does your youngster understand he or she must always ride off-road and without any passengers?
8. Have you stressed to your youngster the importance of keeping his or her feet on the footrests?

If you have completely covered all these areas, you are ready to go on to Part 3.

LEARNING AREA/RIDING AREA

Carefully observe your youngster's first use of the ATV. Observe his or her readiness to ride. Only permit your youngster to continue riding if he or she has the size, strength, and attitude needed to ride safely.

Your youngster's feet must stay on the footrests at all times. Be sure to stress this important rule. If a foot comes in contact with the ground, it may be run over by the rear tire.

Show your youngster the engine, exhaust pipe, and muffler. Tell him or her not to touch these parts because they are hot while the engine is running. Explain that they will remain hot for some time after the engine is stopped. Also explain that hands and feet must be kept away from moving parts of the ATV.

Your youngster's safety depends in part on the condition of the ATV. Be sure to inspect it before each use. Starting and refueling of the vehicle should be done by responsible adults only. Follow a regular maintenance program. See the owner's manual for inspection details.

Even after young riders have learned the basic

riding skills, direct supervision by an experienced adult is necessary AT ALL TIMES. Make sure that all ATV users under your supervision get proper riding instructions. Stress that an ATV is not a toy. Follow safety precautions strictly to provide a "safety-first" approach to ATV riding. Teaching your youngster how to ride an ATV safely will increase the enjoyment of ATV riding.

The best place for learning is a level area 100' x 200' (30m x 60m) that is free from obstacles such as rocks, stumps, or holes. The learning area may have a loose or hard dirt surface. A grassy surface is also acceptable. It should not have two different surfaces. **Under no circumstances should the surface be concrete or asphalt.** ATVs are not designed to be used on paved surfaces because pavement may seriously affect handling and control.

Be sure there is room enough to maneuver, and that no other riders are close by. And remember, ATVs are not designed for use on public roads and other motorists may not see you.



PARENTS, YOUNGSTERS & ALL-TERRAIN VEHICLES

GETTING USED TO THE VEHICLE IN MOTION

Getting the Feel of the Brakes

Be sure your youngster is wearing all of the proper protective gear. With the engine OFF, have your youngster set the parking brake and mount the ATV from the side. Then have your youngster release the parking brake, and if you physically can, push the ATV slowly. Have your youngster brake to feel how much pressure is needed for a smooth stop. If your youngster's ATV has more than one brake control, both should be applied with even pressure. Practice this several times until you are sure this skill is developed. Remind your youngster to keep his or her head up, look forward; and keep both feet on the footrests.

Getting the Feel of the Throttle and Brake Controls

With the engine OFF, have your youngster practice smoothly moving the throttle control lever. Your youngster will learn how much throttle it takes to start moving in a later exercise. Explain that pushing the throttle will increase speed.

Releasing the throttle and applying the brakes will slow the ATV. Ask your youngster to tell you how throttle control and braking affect the ATV's speed.

Getting the Feel of Turning

Have your youngster practice the following turning technique, first with the ATV stopped and the engine OFF:

1. Look in the direction of the turn.
2. Turn the handlebars in the direction of the turn.
3. Move your body weight forward and to the inside of the turn.

Repeat this exercise while you are slowly pushing your youngster on the ATV. Make sure he or she can turn the vehicle in both directions using this technique.

Being Prepared for Riding Practice

Be sure you observe all the safety precautions covered in the Introduction and Parts 1 and 2. Double-check that the riding area is free of hazards. Your youngster should wear all the proper protective gear, and the speed limiter (if equipped) should be installed and working correctly. Make certain the parking brake is set before your youngster mounts the ATV. This will help prevent the ATV from moving until everything is ready. Some ATV manufacturers

have equipped their youth ATVs with a remote engine stop switch. This allows the supervisor to follow close behind and stop the engine by pulling a tethered cord. If the ATV is equipped with a tether, practice using it when your youngster first starts riding. Pull the tether after the ATV is moving. The ATV may continue to roll for some distance. Watch the distance until the ATV stops. Be aware that this distance must be included in the stopping space of the ATV and that this distance will increase with speed.



Starting the ATV

Always start the ATV for your youngster. To remember the proper starting technique, use the following: "BONE-C."

Double-check that the parking brake is set. Start the engine. Have your youngster carefully mount from the side of the ATV. Let your youngster operate

B	BRAKE	Set the parking brake.
O	ON	Ignition and fuel on.
N	NEUTRAL	ATV in neutral (if equipped)
E	ENGINE	Stop switch in run/on start position. Check your owner's manual for your model ATV.
C	CHOKE	On (for cold engine only)

the engine stop switch to shut off the engine. Re-start the ATV and repeat shutting off the engine. Re-start the engine. Allow the engine to warm up until it runs smoothly with the choke off.

Walk next to the ATV when your youngster first starts riding. You can also let the beginner ride back and forth between you and another adult. If your youngster's ATV is equipped with a tether stop switch, you should hold it firmly in your hand before the youngster starts. Help your youngster with the turns as he or she practices throttle control and braking. To turn the ATV around for your youngster, have him or her set the parking brake and dismount from the vehicle. You can then drag the back end of the ATV into position.



Starting Out and Stopping

Be sure the parking brake is still set. If the ATV comes equipped with a tether stop switch, be sure you connect it. Have your youngster perform the following:

1. Squeeze the brake lever and apply the foot brake (if equipped). NOTE: Tell your youngster that he or she now controls the brakes.
2. While continuing to hold the brakes, shift into first gear (if equipped with a shift lever). NOTE: If the ATV has a shift lever, be sure your youngster releases the throttle control lever, moves the shift lever into first gear, and then removes pressure from the shift lever.
3. Slowly release the brakes, and then push the throttle control lever until the ATV starts moving.
4. Move forward slowly as you supervise closely. Stay in first gear. Release the throttle and apply the brakes, make a smooth stop.
5. Repeat several times.

Be sure your youngster develops smooth use of the throttle control. Speed can be increased once your youngster has mastered starting and stopping at slow speeds.

Turning

Remind your youngster of the turning sequence:

1. Look in the direction of the turn.
2. Turn the handlebars in the direction of the turn.
3. Move your body weight forward and to the inside of the turn.

Have your youngster practice turning in both directions at slow speeds. Allow enough room to make a wide turn. After your youngster has mastered making wide turns, have him or her practice tighter turns.



Keep Speed Slow

Your youngster should master these skills at low speeds before going faster. Consider using a figure-eight path. This will help your youngster make left and right turns one after another. Make sure your youngster keeps both feet on the footrests and looks ahead in the direction of the turn. Check for proper weight shift in the turns. As skill develops and practice continues, be sure to closely supervise all riding.

Once these skills are mastered, refer to the ***Tips and Practice Guide for the All-Terrain Vehicle Rider*** for additional skills used in ATV riding.

This Readiness Checklist is provided to help you determine your youngster's readiness to learn to safely operate and control an ATV. There is a significant amount of judgment needed in determining a youngster's readiness to ride an ATV. The ultimate decision is the responsibility of the parent, guardian, or supervising adult. It is important that parents make informed decisions about whether or not their youngster becomes involved in ATV activity.

There are four developmental areas considered in the Readiness Checklist. These include: visual perception/motor development; physical development; social/emotional development; and reasoning and decision-making ability. Several questions are listed to help you determine if your youngster possesses the skills and capabilities to safely learn to operate an ATV.

The best way to utilize the Readiness Checklist is to read the particular ability, consider the answers to the questions for that ability, and check those abilities that you determine your youngster possesses. There are no suggestions as to how many abilities or the degree of ability that your youngster should have. This Readiness Checklist may help you consider the appropriateness of ATV operation for your child. The ultimate decision for your youngster's involvement with ATVs belongs to you, the parent.

READINESS CHECKLIST *(CONTINUED)*

24

Visual Perception/Motor Development Ability

Points to Evaluate

1. Youngster can see with sufficient clarity.

- Can youngster see letters and numbers at least as well as you?
- Can youngster distinguish colors?
- Has youngster demonstrated adequate vision in other activities (riding bicycles, running, team sports, or other recreational activities)?

2. Youngster possesses ability to perceive depth or distance.

- When looking at two objects in the distance, can youngster tell which is farther away and which is closer?

3. Youngster has adequate side vision/peripheral vision.

- Can youngster see objects 90 degrees to each side while looking straight ahead?

4. Youngster can judge the speed of objects.

- Does the youngster judge the speed of objects (fast, medium, slow) that agree with your judgments? (For example, a car on the highway, a train moving past a crossing, a dog running, people walking.)

5. Youngster can state the distances of objects in terms of feet, yards, miles.

- Can youngster tell how many feet or yards it is from the house to the road?
- Can youngster tell how wide a hallway is, or the width of a room?

6. Youngster can follow movement of objects.

- Can youngster follow the path of such things as: a hit or thrown baseball, a moving car, objects in a video game?

7. Youngster can visualize distances as displayed by a picture or photograph.

- Can youngster estimate distance between objects in a photograph?
- Can youngster estimate distance between objects when looking at a landscape picture?

8. Youngster can follow a moving object while accomplishing hand manipulation.

- Can youngster dribble a basketball without looking at it?
- Can youngster manipulate video game controls while following objects on a screen?

9. Youngster can maintain relative spans of attention when given a variety of stimuli.

- Can youngster complete school homework assignments without being easily distracted?
- Can youngster assemble more difficult puzzles; for example, a nature scene or picture?

Physical Development

Points to Evaluate

1. Youngster can sit comfortably on the ATV and reach the controls easily.

- Can youngster place his or her feet firmly the footrests?
- Do the youngster's fingers reach comfortably around the handlebars and brake lever(s)? How about with the handlebars turned? How about in different seating positions?
- Can youngster stand (with knees slightly bent) and have at least three inches of space above the seat?
- Can youngster easily reach the foot controls?
- Can youngster dress with proper protective gear including putting on helmet and fastening the chin strap?

READINESS CHECKLIST *(CONTINUED)*

26

2. Youngster has sufficient strength and familiarity to operate the controls with ease.

While sitting on the vehicle, can youngster:

- Squeeze hand controls?
- Operate the shift lever (if equipped)?
- Operate the parking brake?
- Operate the choke and fuel valve with ease?
- Press the brake lever with sufficient pressure?
- Operate the controls without looking at them?

3. Youngster is sufficiently coordinated.

- Can youngster walk a “balance beam” (2 in. x 4 in. x 8 ft.) flat on floor?
- Can youngster ride a bicycle, roller skate or skateboard safely?
- Can youngster walk on tiptoes for 10 feet?
- Can youngster jump rope?
- Can youngster catch a ball with hands rather

than with arms?

4. Youngster has sufficient endurance to maintain strength over a period of time.

- Can youngster play outdoor games without fatigue?
- Can youngster participate in indoor games and sports without tiring before other youngsters?

Social/Emotional Development **Points to Evaluate**

1. Youngster can understand and follow rules.

- Does youngster follow rules established at home?
- Do teachers say that the youngster follows rules?
- Does youngster listen and respond to adult supervision?
- Does youngster comprehend the importance and seriousness of having rules and regulations?

2. Youngster generally will obey parents and supervisors.

- Does youngster avoid challenging authority or rebelling when rules are imposed?

3. Youngster controls behavior according to expectations.

- Does youngster show evidence of self-control; doesn't get easily frustrated or upset?
- Does youngster understand consequences associated with certain actions (like not wearing a safety belt in the car)?
- Does youngster think about results of an action before performing it (like crossing the street; hitting or throwing a ball)?

4. Youngster understands other youngsters may be permitted to do what he/she may not be allowed to.

- Does youngster recognize unsafe actions of other youngsters?

- Does youngster appreciate being safer than others?
- Does youngster accept rules that are more stringent than what other youngsters have to follow?

5. Youngster can give reasons and/or solutions to problems seen in the environment.

- Can youngster explain how land (or grass) gets damaged?
- Can youngster explain how even a small amount of damage to land can take years to recover?
- Can youngster distinguish between untouched land and used land?

6. Youngster can make decisions based on reality and not fantasy.

- Can youngster complete a task in a step-by-step fashion (assemble a toy, clean a room)?

READINESS CHECKLIST *(CONTINUED)*

28

- Does youngster comprehend real injury as opposed to “cartoon” injury?
- Does youngster respond with logical solutions when asked to solve a problem?

Reasoning and Decision-Making Ability

Points to Evaluate

1. Youngster comprehends that interaction with others and things can result in injury.

- Can youngster describe how and why a person received physical injury or pain?
- Does youngster notice impending accidents or potential injury-producing events, such as in sports activities or bicycle riding?
- Can youngster explain why it takes distance to stop?
- Can youngster explain how moving at even low speed can result in injury if stopped

suddenly or by hitting something?

2. Youngster has a basic understanding of what being careful means.

- Does youngster know why rules are established?
- Does youngster notice or recognize others being careful in action-oriented activities?
- Does youngster notice professional athletes use protective gear as part of their sport?

3. Youngster understands that rules are made to reduce injury and provide long-term enjoyment.

- Can youngster explain the reason for rules at home or school?
- Does youngster understand the value of prevention? Of wearing protective gear?
- Can youngster recognize that not following rules can eliminate future fun and

enjoyment?

4. Youngster has basic understanding of the physical limitations of stopping and turning.

- Can youngster explain what may happen if moving too fast while going around a curve on a bicycle? On a skateboard? On an ATV?

5. Youngster can describe cause-and-effect experiences.

- Can youngster describe a minor injury he or she received and correctly describe the causes?
- Can youngster describe settings or situations that can produce injury if precautions are not taken?
- Can youngster describe what may cause injury when doing such things as running, swimming, bicycling, riding in a car?

6. Youngster can concentrate on more than one element at a time in solving a puzzle or problem.

- Can youngster pick out or describe several items within a picture?
- Can youngster assemble a puzzle without unusual problems or delays?
- Can youngster describe what to do if a house fire should occur?

FINAL NOTE TO PARENTS

30

We hope this booklet has helped you and your youngster take a “safety-first” approach to ATV riding. All ATV riders must use good judgment and be responsible. It is up to YOU to set a good example for ATV safety. You must help your youngster to ride sensibly and safely at all times.

After your youngster has mastered the riding skills in this booklet and has matured to a higher level of skills, he or she may be ready to practice more advanced riding. The ASI’s ***Tips and Practice Guide for the All-Terrain Vehicle Rider*** booklet provides information about riding on hills, riding across slopes and other more advanced skills. Youngsters should have a good understanding of riding skills before riding in unfamiliar areas. They should ride on flat areas, gentle hills and gradual slopes.

Be sure that your youngster rides slowly over unfamiliar terrain to locate and avoid bumps, holes and other possible obstacles. You should check the area first.

It is also recommended that you and your youngster read the information in the owner’s manual.

View and download ***Tips and Practice Guide for the All-Terrain Vehicle Rider*** online at atvsafety.org.

Single copies are also available free by contacting:

ATV Safety Institute
2 Jenner, Suite 150, Irvine, CA 92618-3812
949.727.3727

To purchase large quantities of the booklet, contact ASI for prices.

To enroll in the ATV RiderCourse nearest you, visit atvsafety.org/reserve-your-seat or call 800.887.2887.

Video Resources

Watching these videos is only a first step; completing our online course and taking our hands-on training are the best ways to prepare riders for their ATV journey. The ATV Safety Institute RiderCourse accommodates riders age 6 and up.

Ride Safe, Ride Smart: For All ATV Riders

This seven-minute video demonstrates the importance of getting a proper start in ATV riding,

whether you ride ATVs for recreation or for business. The family profiled in the video understands that while ATVs are fun, the activity needs to be approached with a safety-first attitude, and they follow the ATV Safety Institute's Golden Rules to help them get the most out of every ATV adventure.

Ride Safe, Ride Smart: For Young ATV Riders

ATV riding is a great way for families to enjoy the great outdoors. Many families purchase ATVs for their children under the age of 16, and this video is made for those young riders. The host presents special considerations the young riders and their parents need to be aware of to help ensure the youngsters' safety when riding. Matching the vehicle to the age of the child and supervising them during EVERY ride are key components of safe riding.

Visit ATVsafety.org/RideSafeRideSmart or scan the code to watch both videos.

Additionally, both videos are available on a DVD, in English and Spanish. Single copies are free; to purchase large quantities contact ASI.



SCAN TO WATCH

TREAD Lightly!

Riding behavior that harms the land is self-defeating and irresponsible. Learn to protect and preserve your riding areas. In other words, TREAD Lightly!

- **T**Travel responsibly on designated roads and trails or in permitted areas.
- **R**espect the rights of others including private property owners and all recreational trail users, campers and others to allow them to enjoy their recreational activities undisturbed.
- **E**ducate yourself prior to your trip by obtaining travel maps and regulations from public agencies, planning for your trip, taking recreation skills

FINAL NOTE TO PARENTS *(CONTINUED)*

classes, and knowing how to use and operate your equipment safely.

- **A**void sensitive areas such as meadows, lakeshores, wetlands and streams, unless on designated routes. This protects wildlife habitat and sensitive soils from damage.
- **D**o your part by leaving the area better than you found it, properly disposing of waste, minimizing the use of fire, avoiding the spread of invasive species, restoring degraded areas, and joining a local enthusiast organization.

ALL-TERRAIN VEHICLE (ATV) - Any motorized off-highway vehicle designed to travel on four low-pressure tires, having a seat designed to be straddled by the operator and handlebars for steering control.

AXLE - The shaft on which the rear wheels are mounted.

BONE-C - A pre-start routine. A way to remember the pre-start routine:

B - Brake (set parking brake)

O - On (fuel and ignition on)

N - Neutral

E - Engine Stop Switch

C - Choke

BRAKES - The parts of an ATV that allow the operator to slow down or stop the machine.

BRAKE LEVER - The hand brake located on the handlebar.

BRAKE PEDAL - The foot brake that is operated by the right foot.

CABLES - Heavy insulated wires. There are two kinds: mechanical and electrical. Brake cables are mechanical. The headlamp cable is electrical.

CARBURETOR - Device that provides the proper mixture of fuel and air to the engine.

CHOKE - A device that enriches the mixture of gasoline and air supplied to the engine for cold-engine starting.

DRIVE CHAIN - The chain that connects the engine to the rear axle to give an ATV motion.

DRIVE SHAFT - A shaft device used to transmit power to the rear axle to give an ATV motion.

ENGINE STOP SWITCH - Switch used to stop the engine without removing the hands from the handlebars.

EXHAUST - Leftover gases from the combustion process that come out of the tailpipe when the ATV engine is running. Exhaust contains deadly carbon monoxide gas.

GLOSSARY OF ATV TERMS *(CONTINUED)*

EYE PROTECTION - Goggles or a shatter-resistant shield worn over the eyes while riding to protect against dust, flying insects, or other debris. Such eye protection, when tinted, may be effective against bright sun or snow-glare conditions.

FLOODING - A condition that occurs because of improper fuel and air mixture, resulting in the engine not starting.

FOOTREST - Horizontal bar or platform on which ATV operators should keep their feet while riding.

FUEL VALVE - A valve, usually hand operated, with an on, off and "reserve" position. Controls gasoline flow to the carburetor.

HANDLEBAR - The metal bar attached to the front end of the ATV that turns the front wheels for steering. Many of the controls for the ATV are located on the handlebar.

HELMET - The most important item of protective clothing to be worn when operating an ATV. It covers the head and helps protect against skull fracture or brain injury in an accident.

OFF-HIGHWAY or OFF-ROAD VEHICLE - Any vehicle, including off-highway motorcycles and ATVs, that is restricted by law from operating on public roads.

PARKING BRAKE - A mechanism that holds the brake in the on position.

PSI - Refers to air pressure in the tires and stands for "Pounds per Square Inch."

RECOIL STARTER - The pull-cord mechanism used to start some ATV engines.

READING THE TERRAIN - Looking well ahead while riding; anticipating hazards.

RPM - "Revolutions per minute"; used to describe the engine speed.

SHIFT - On those ATVs equipped with a shift lever, it allows the operator to change gears. The shift lever is operated by the left foot.

SHOWOFF - A careless, thoughtless rider who operates an ATV without regard for the personal safety or private property of others, usually for the purpose of getting attention.

SPARK PLUG - A user-serviceable part within the engine that provides the spark for ignition.

SWITCHBACK - A sharp curve on a trail. Used to change direction, usually on steep hillsides.

TAILPIPE - That part of the exhaust system that expels waste gases.

THROTTLE - The control operated by the right hand or thumb that controls the engine speed.

TRACTION - Tread friction between the ground and the tires.

TRANSMISSION - The series of gears, shafts, belts, chains and sprockets used to transmit power from the engine to the wheels.

WEIGHT TRANSFER - Change in rider weight distribution to control an ATV while maneuvering.

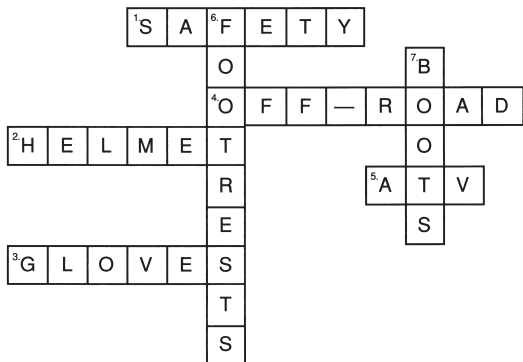

1. Parking Brake
2. Hand Brake Lever(s)
3. Foot Brake Pedal
4. Throttle
5. Ignition Switch
6. Choke (primer)
7. Engine Stop Switch
8. Gas Cap/Tank Vent
9. Starter (pull, kick, electric)

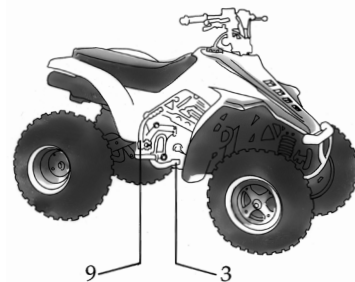
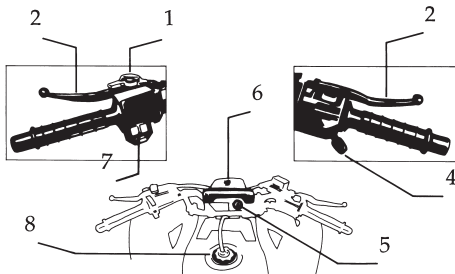



To enroll in the *ATV RiderCourse* nearest you, visit atvsafety.org/reserve-your-seat or call: (800) 887-2887

atvsafety.org

Specialty Vehicle Institute of America
2 Jenner, Suite 150 • Irvine, CA 92618